

CNC Double Column Machining Center

Linear Guide Series

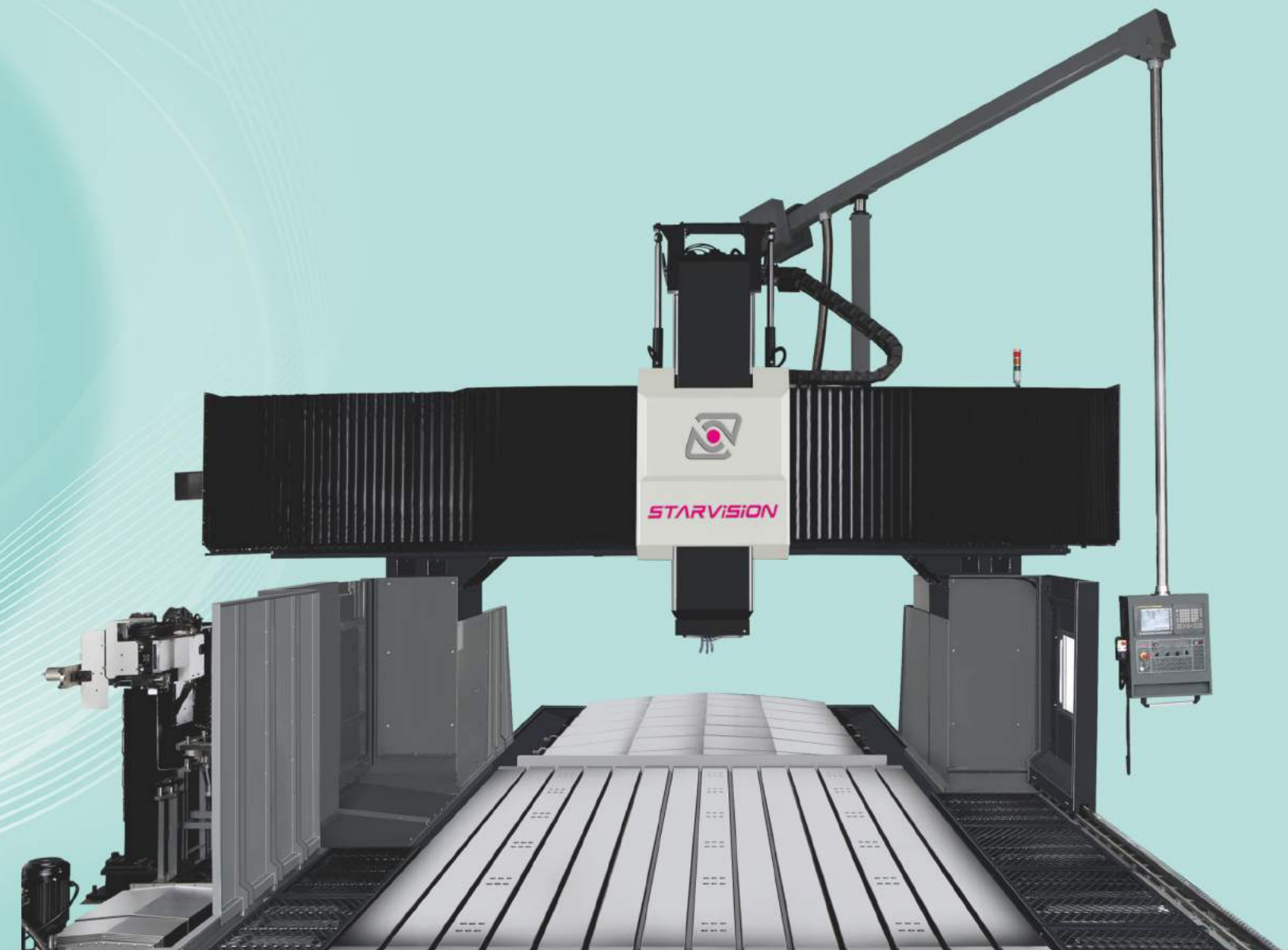



PURSUE EXCELLENCE. STRIVE TO DO BETTER.

Starvision carries 20 years of professional experience in R&D, assembly, quality control and marketing Double Column Machining Center.

In 2008, we have signed a technical cooperation agreement with well-known German turning machine manufacturer A. Monforts Werkzeugmaschinen GmbH and arranged an off-site training in Monforts Germany.

Starvision team integrates advanced technology and strict attitude into our own products. We set ourselves very high standards and always keep up constant know-how exchanges and innovations. These not only enhance our own technology but also strengthen our faith and passion to machine tool industry.

Concentrate on the quality of our product and fulfill the needs of our customers.

Our goal is, with support from the best suppliers, making a concerted effort to offer the best Starvision Double Column Machining Center to our customers.

SUSTAINABILITY
More than selling products,
Starvision persists in sustainable operation.

SHARING
More than selling products,
Starvision shares professional experience.

INTEGRITY
More than selling products,
Starvision fulfills the promise.

SERVICE
More than selling products,
Starvision carries through after-sales responsibilities.

Box way FS series
Z-axis 800 (opt.1,000) mm
Y-axis 1,600 / 2,000mm
X-axis 2,200 - 4,200mm

Box way PC series
Z-axis 1,000 (opt.1,200) mm
Y-axis 2,300 / 2,600mm
X-axis 3,200 - 6,000mm

Linear way DX series
Z-axis 800 (opt.1,000) mm
Y-axis 1,600 / 2,000mm
X-axis 2,200 - 4,200mm

Linear way LG series
Z-axis 1,000 (opt.1,200) mm
Y-axis 2,300 / 2,600mm
X-axis 3,200 - 6,200mm

Linear way FG series
Z-axis 1,000 (opt.1,200) mm
Y-axis 2,600mm
X-axis 3,200 - 10,200mm

Linear way LS series
Z-axis 1,000 (opt.1,200 / 1,500) mm
Y-axis 3,000 / 3,500 / 4,000 / 4,500mm
X-axis 4,200 - 10,200mm

Crossbeam Moving SBM series
Z-axis 1,000 (opt.1,200 / 1,500) mm
W-axis 1,000 (opt.1,250 / 1,500) mm
Y-axis 2,800 - 5,300mm
X-axis 4,200 - 10,200mm

Column Moving CM series
Z-axis 1,000 (opt.1,200 / 1,500) mm
Y-axis 3,700 / 4,700 / 5,700mm
X-axis 6,200 - 36,200mm

DX-SERIES

Linear Guide Series

HIGH SPEED. FAST AND PRECISE.

DX Series is built for efficiency, featuring both high speed and accuracy. With linear guide way design which can achieve a long service life with high accuracy, DX Series is your perfect solution for efficient machining and fast cutting.



2 x 1.4m - 4 x 1.7m



1.7m / 2.1m

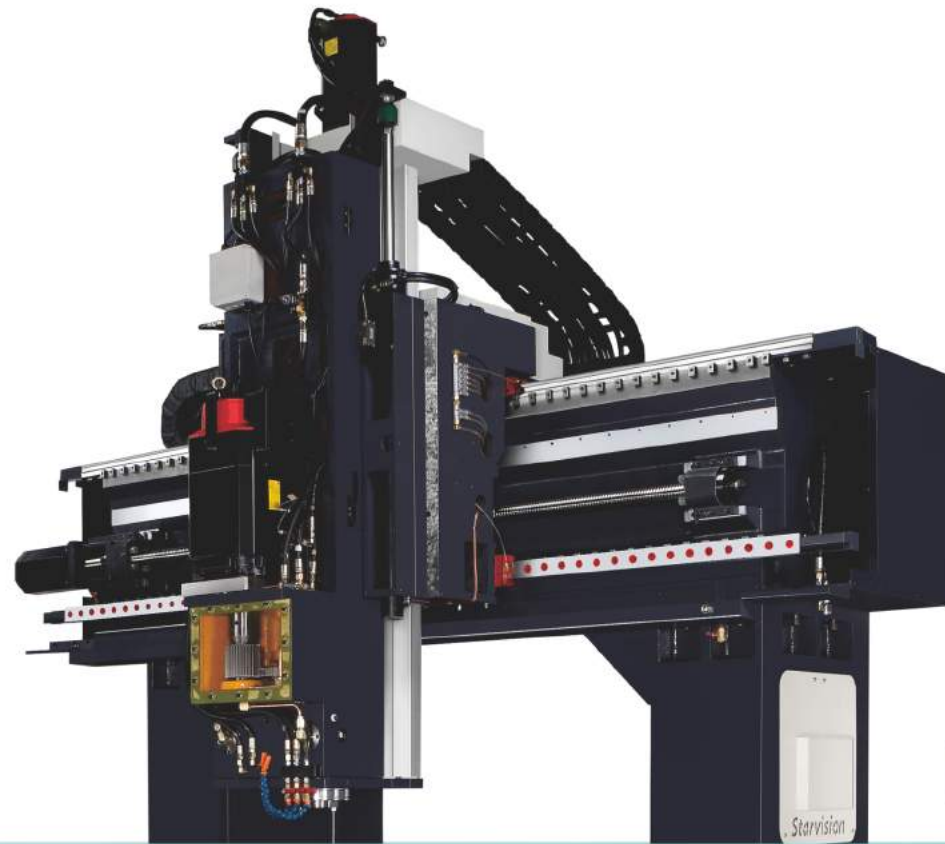

schnell

(24T is optional)

GREAT PERFORMANCE.

Starvision uses advanced design systems including FEA and 3D CAD Modeling to design our machine. LG (Linear Guide way) Series is equipped with two sets of optimal R65 linear guide way in X and Y axis. It is not only reliable, but also represents high value and great performance.

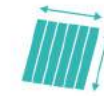

3 x 2m - 6 x 2m



2.5m / 2.8m



stark

(Fully enclosed splash guard with roof is optional)

FG-SERIES

Linear Guide Series

STABLE IN ACCURACY. FLEXIBLE IN LENGTH.

FG Series is an extension of LG series. The base is equipped with three sets of R55 linear guide way, a wider working table and a prolonged X travel up to 10,200mm. Our intention is to offer the customer another choice for medium to large size workpiece machining.

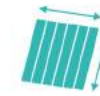

3 x 2.4m - 10 x 2.4m



2.8m



fortschrittlich

(HEIDENHAIN controller is optional)

LARGE CAPACITY.

LS (Large Space) Series has very rigid structure, with three sets of R65 linear guide way in X axis, ensuring a stable axial movement. It is your best choice for large to extra-large size workpiece machining and is suitable for all kinds of mold application.

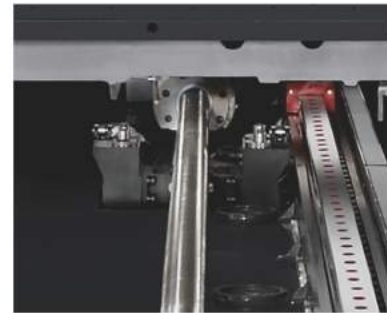

- Ball screw support unit for travel over 5m in X axis



- WITTENSTEIN alpha planetary gearhead represents stability and accuracy



4 x 2.8m - 10 x 2.8m (3.5m opt.)



3.2m / 3.7m

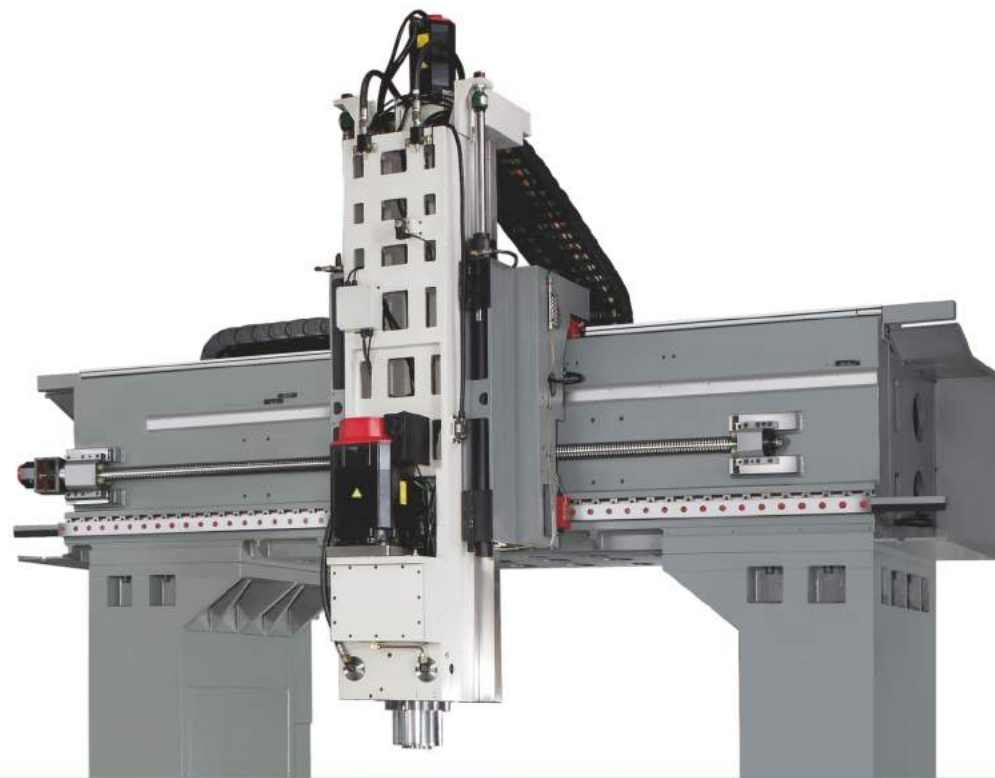

breit

(Fully enclosed splash guard, AHS, V/H ATC, higher suspension type controller panel are optional)

LS-SERIES

Linear Guide Series

**MORE OPTIONS.
DIFFERENT PACKAGES.
VARIOUS APPLICATIONS.**



breit

(Higher suspension type controller panel is optional)

» Ballscrew Support

For X travel over 5 meters (inclusive) and Y travel over 3.5 meters (inclusive) machine, we will offer an extra ballscrew support for better support and to reduce the deformation. This device will also enhance the bearing life.

» Distance Between Columns

From 3,200 to 4,700mm to meet different customer's machining requirements.

» Headstock (LS-XX40/45)

Box in box structure design with square type ribs inside which not only efficiently reduces the weight of headstock but also enhances the geometric and thermal stability of the machine, showing excellent machining rigidity. With an upper mounted spindle motor design, we can install a bigger motor to receive more powerful torque without worrying the possible machining interference.

- Headstock size: 500x500mm
- Standard 1,000mm Z travel with 2x R65 roller type linear guide ways
- Optional 1,200/1,500mm Z travel with 4x roller type linear guide ways (size R55 and R65)

» Linear Guideway

X axis is equipped with triple R65 roller type linear guide ways for high rigidity and precision and to achieve a long service life with highly accurate motion.

» Gear Reducer

Gear transmission for the X axis with gear ratio 1: 3 for less than 4 meters models and gear ratio 1:4 for 5 meters and above models. With planetary gear reducer, the axial movement is able to respond effectively.

» Base

- Lubricant recycling to keep the base clean
- Lubricant and coolant separation to prolong the service life of the coolant
- Complete chip management system to avoid damage to the guide way

» Spindle Torque

(LS-XX40/45)

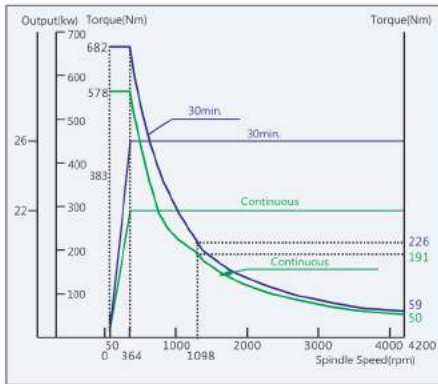

Spindle motor torque chart
Motor: FANUC α 22
2-step gear type spindle

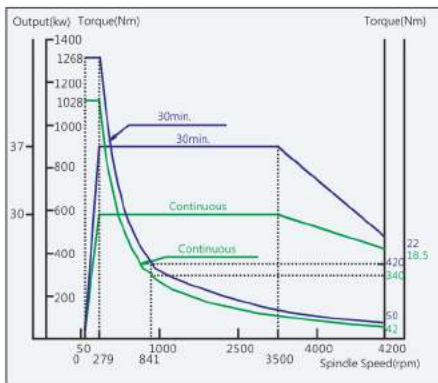

Spindle motor torque chart
Motor: FANUC α 30
2-step gear type spindle



High Precision Spindles

Various spindle motor selection, featuring high torque, low temperature-rise and long service life, meets different customers' machining requests.



Long nose

Gear drive spindle



Short nose

Gear drive spindle



Direct drive spindle BT 50



Direct drive spindle BT 40

(Big ceramic bearing)



2-step Gearbox

- Using made in Japan JIS Class 0 gears
- High efficiency power transmission
- Great torque output
- All the bearings, gears and spindle have forced lubrication system to ensure a smooth operation of the gearbox and to make sure a constant temperature at all times

All New Headstock Design Offers Various Spindle Torques

Spindle Torque

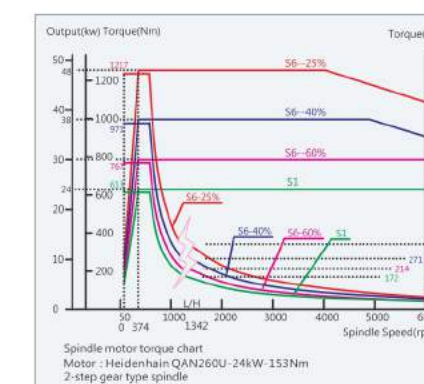
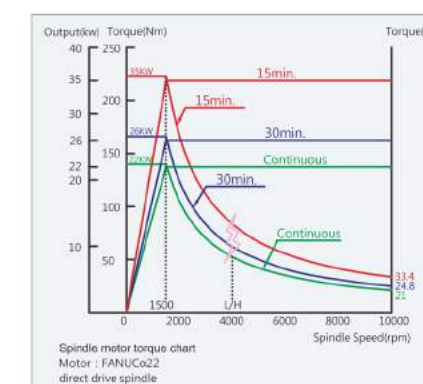
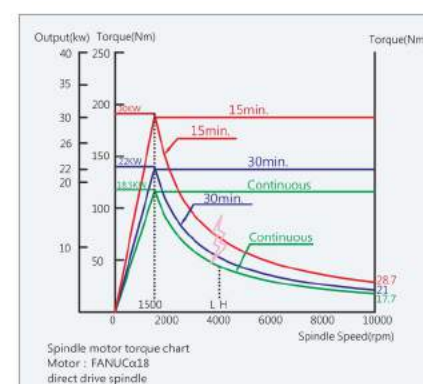
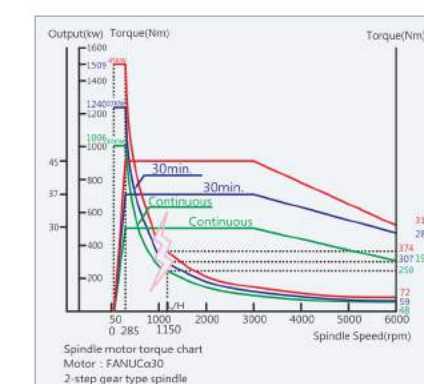
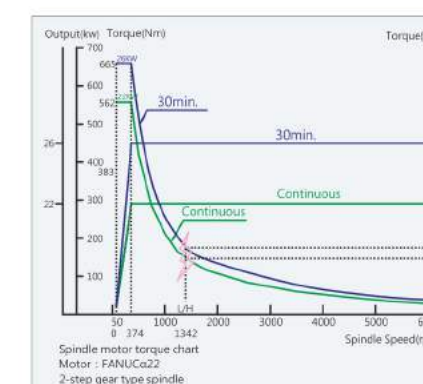
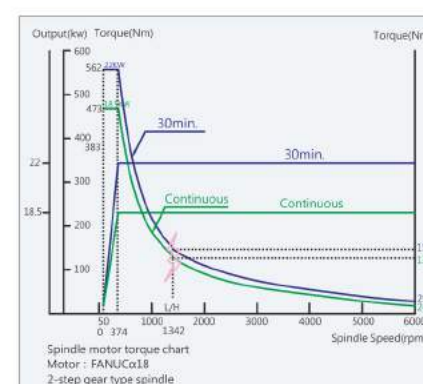



Safety Walkway Standard for user-friendly operation and safety



Organized Electrical Cabinet

- Conforms to CE safety regulation.
- Fully enclosed design.
- Equipped with a heat exchanger to maintain stable temperature.
- Alarm message and self-diagnosis functions provide safety protection during operation and maintenance.



Convenient Quick Plug

- One step connection
- Easy maintenance
- Great protection



Energy Saving Z Axis Balance System

Z axis movement is counter-balanced by twin hydraulic cylinder and nitrogen accumulator. An bladder accumulator can equilibrate hydraulic pulsation caused pressure, such as hysteresis caused overcut. When abnormal power outage occurs, the Z axis position can be secured. The whole system not only enhances the sensitivity of the Z-axis micro-movement, showing great flexibility and best dynamic stability, but also ensures the machine's optimal repeatability. In addition, it helps the energy saving up to 30%.

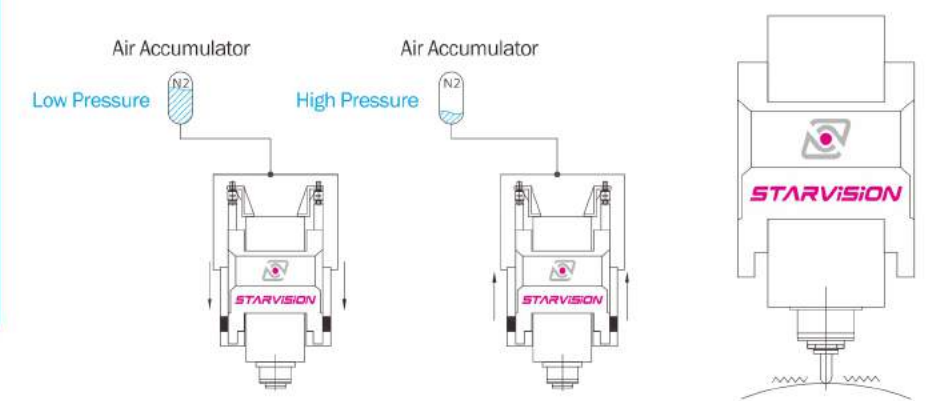

AC Automatic Clamping



MC Automatic Indexing & Manual Clamping



MH Manual Head



Testing Machine

We have this special testing machine to make sure every milling head you purchased is carefully assembled and fully tested at Starvision. Moreover, this machine is also participated in continuing development and improvement of our milling heads.

Splash Guard Selection



Semi Splash Guard



Fully Enclosed Splash Guard Without Roof



Fully Enclosed Splash Guard With Roof

AC Series Milling Heads

With AHS Automatic head station, a fully automatic solution realizes optimum machining efficiency.

- AHS(H)- one head and one cover at operator side
- AHS(S)- multi heads and one cover at ATC side





Table and T-Slot Dimensions

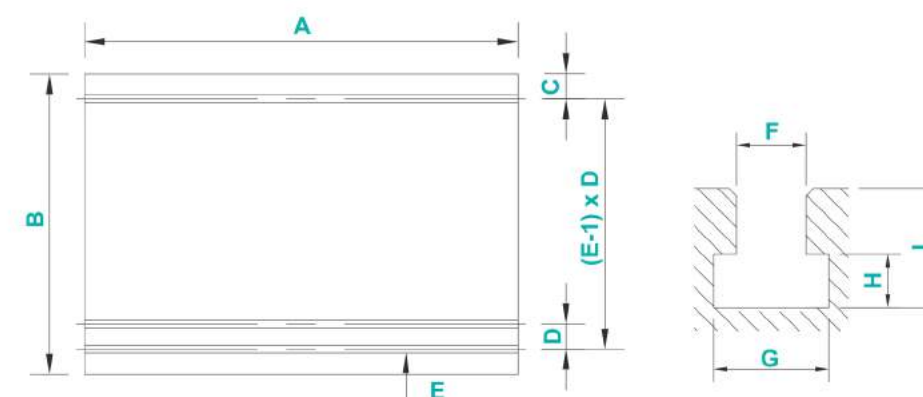

Model	Unit	A	B	C	D	E	F	G	H	I
DX-2216	mm	2,000	1,400	160	180	7	22H8	38	16	38
DX-2716	mm	2,500	1,400	160	180	7	22H8	38	16	38
DX-3216	mm	3,000	1,400	160	180	7	22H8	38	16	38
DX-4216	mm	4,000	1,400	160	180	7	22H8	38	16	38
DX-2220	mm	2,000	1,700	130	180	9	22H8	38	16	38
DX-2720	mm	2,500	1,700	130	180	9	22H8	38	16	38
DX-3220	mm	3,000	1,700	130	180	9	22H8	38	16	38
DX-4220	mm	4,000	1,700	130	180	9	22H8	38	16	38
LG-3223/26	mm	3,000	2,000	100	180	11	28H8	48	22	52
LG-4223/26	mm	4,000	2,000	100	180	11	28H8	48	22	52
LG-5223/26	mm	5,000	2,000	100	180	11	28H8	48	22	52
LG-6223/26	mm	6,000	2,000	100	180	11	28H8	48	22	52
FG-3226	mm	3,000	2,400	120	180	13	28H8	48	22	52
FG-4226	mm	4,000	2,400	120	180	13	28H8	48	22	52
FG-5226	mm	5,000	2,400	120	180	13	28H8	48	22	52
FG-6226	mm	6,000	2,400	120	180	13	28H8	48	22	52
FG-8226	mm	8,000	2,400	120	180	13	28H8	48	22	52
FG-10226	mm	10,000	2,400	120	180	13	28H8	48	22	52
LS-4230/35/40/45	mm	4,000	2,800	400	200	13	28H8	48	22	52
LS-5230/35/40/45	mm	5,000	2,800	400	200	13	28H8	48	22	52
LS-6230/35/40/45	mm	6,000	2,800	400	200	13	28H8	48	22	52
LS-8230/35/40/45	mm	8,000	2,800	400	200	13	28H8	48	22	52
LS-10230/35/40/45	mm	10,000	2,800	400	200	13	28H8	48	22	52

Automotive Industry



Aerospace Industry

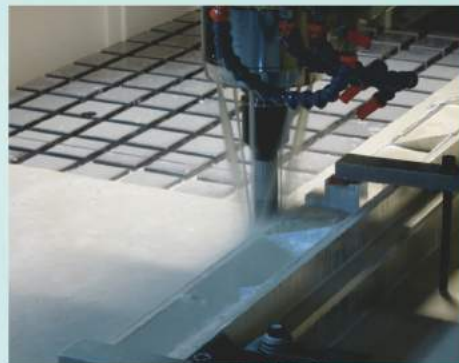

Electronics Industry



Mold Industry



Industrial Machining



DX series

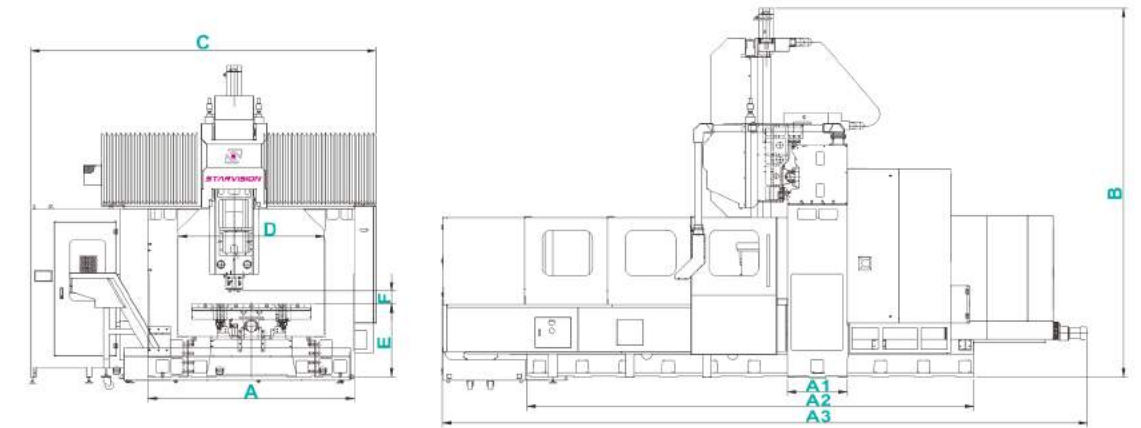

Model	Unit	A	B	C	D	E	F	A1	A2	A3
DX-2216	mm	2,400	4,700	4,100	1,700	850	150	700	4,200	6,700
DX-2716	mm	2,400	4,700	4,100	1,700	850	150	700	5,200	7,700
DX-3216	mm	2,400	4,700	4,100	1,700	850	150	700	6,200	8,700
DX-4216	mm	2,400	4,700	4,100	1,700	850	150	700	8,200	10,700
DX-2220	mm	2,800	4,700	4,500	2,100	850	150	700	4,200	6,700
DX-2720	mm	2,800	4,700	4,500	2,100	850	150	700	5,200	7,700
DX-3220	mm	2,800	4,700	4,500	2,100	850	150	700	6,200	8,700
DX-4220	mm	2,800	4,700	4,500	2,100	850	150	700	8,200	10,700

Model	Unit	DX-2216 / 20	DX-2716 / 20	DX-3216 / 20	DX-4216 / 20
Travel					
X axis	mm	2,200	2,700	3,200	4,200
Y axis	mm	1,600 / 2,000			
Z axis	mm	800 (1,000 opt.)			
Spindle nose to table	mm	150 - 950 (150 - 1,150 opt.)			
Distance between columns (max. workpiece width)	mm	1,700 (1,650) / 2,100 (2,050)			
Table					
Table dimensions (L)	mm	2,000	2,500	3,000	4,000
Table dimensions (W)	mm	1,400 / 1,700			
T-slot (width x number x pitch)		22 x 7 x 180 / 22 x 9 x 180			
Max. table load	kg	8,000	9,000	10,000	12,000
Spindle					
Spindle motor (cont. / 30 minute rated)	kW	18.5 / 22 (22 / 26 opt.)			
Spindle speed (gear box)	rpm	4,500 (6,000 opt.)			
Spindle taper		BT-50 / ISO-50 / CAT-50			
Feed					
Rapid feed-rate (X / Y / Z)	m/min	24 / 24 (20) / 15			18 / 24 (20) / 15
Cutting feed-rate	mm/min	7,000 (10,000 opt.)			
Accuracy					
Positioning accuracy	mm	±0.005 / 300; ±0.015 / full travel			
	mm	P0.03		P0.035	
Repeatability	mm	±0.003			
	mm	Ps0.025		Ps0.028	
ATC					
Tool storage capacity	pcs	32T (24T / 40T / 60T opt.)			
Max. tool length	mm	350			
Max. tool weight	kg	20			
Tool size (full tools)	mm	Ø125			
Max. tool size (next pockets empty)	mm	Ø245			
Other					
Power consumption	kVA	65			
Compressed air	kg/cm ²	6.5			
Machine weight (approx.)	tons	19 / 21	21 / 23	23 / 25	27 / 29
Machine floor space (L x W x H)(approx.)	m	8.4 x 5.1 / 5.5 x 4.7	9.4 x 5.1 / 5.5 x 4.7	10.4 x 5.1 / 5.5 x 4.7	12.4 x 5.1 / 5.5 x 4.7

※ All specification are subjected to change without prior notice.

MACHINE SPECIFICATIONS

LG series

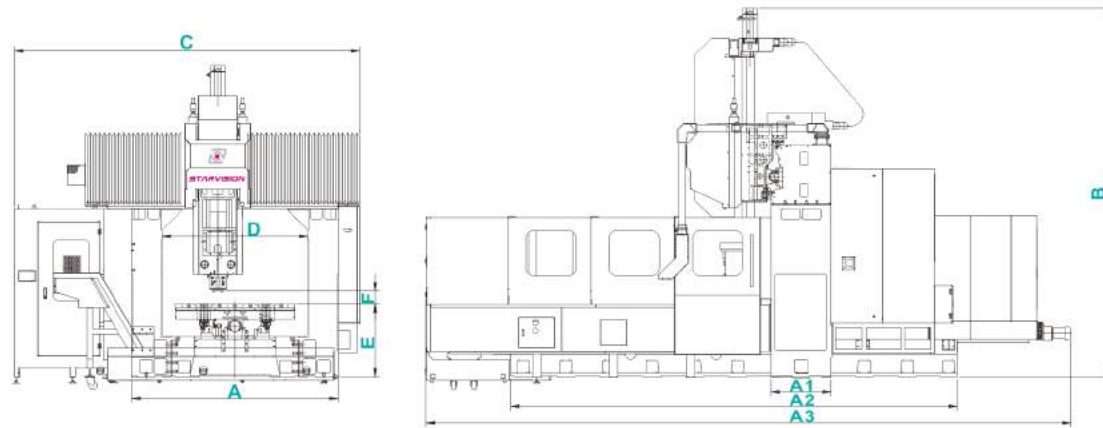

Model	Unit	A	B	C	D	E	F	A1	A2	A3
LG-3223	mm	3,500	5,400	5,500	2,500	950	150	1,000	6,200	8,700
LG-4223	mm	3,500	5,400	5,500	2,500	950	150	1,000	8,200	11,300
LG-5223	mm	3,500	5,400	5,500	2,500	950	150	1,000	10,200	13,100
LG-6223	mm	3,500	5,400	5,500	2,500	950	150	1,000	12,200	15,600
LG-3226	mm	3,800	5,400	5,800	2,800	950	150	1,000	6,200	8,700
LG-4226	mm	3,800	5,400	5,800	2,800	950	150	1,000	8,200	11,300
LG-5226	mm	3,800	5,400	5,800	2,800	950	150	1,000	10,200	13,100
LG-6226	mm	3,800	5,400	5,800	2,800	950	150	1,000	12,200	15,600

Model	Unit	LG-3223 / 26	LG-4223 / 26	LG-5223 / 26	LG-6223 / 26
Travel					
X axis	mm	3,200	4,200	5,200	6,200
Y axis	mm	2,300 / 2,600			
Z axis	mm	1,000 (1,200 opt.)			
Spindle nose to table	mm	150 - 1,150 (150 - 1,350 opt.)			
Distance between columns (max. workpiece width)	mm	2,500 (2,450) / 2,800 (2,750)			
Table					
Table dimensions (L)	mm	3,000	4,000	5,000	6,000
Table dimensions (W)	mm	2,000			
T-slot (width x number x pitch)		28 x 11 x 180			
Max. table load	kg	13,000	15,000	17,000	19,000
Spindle					
Spindle motor (cont. / 30 minute rated)	kW	18.5 / 22 (22 / 26 opt.)			
Spindle speed (gear box)	rpm	4,500 (6,000 opt.)			
Spindle taper		BT-50 / ISO-50 / CAT-50			
Feed					
Rapid feed-rate (X / Y / Z)	m/min	20 / 20 / 15	18 / 20 / 15	12 / 20 / 15	10 / 20 / 15
Cutting feed-rate	mm/min	7,000			
Accuracy					
Positioning accuracy	mm	±0.005 / 300; ±0.015 / full travel			
	mm	P0.035			P0.045
Repeatability	mm	±0.003			
	mm	Ps0.028			Ps0.03
ATC					
Tool storage capacity	pcs	32T (24T / 40T / 60T / 90T opt.)			
Max. tool length	mm	350			
Max. tool weight	kg	20			
Tool size (full tools)	mm	Ø125			
Max. tool size (next pockets empty)	mm	Ø245			
Other					
Power consumption	kVA	65			
Compressed air	kg/cm ²	6.5			
Machine weight (approx.)	tons	34 / 36	38 / 40	44 / 46	50 / 52
Machine floor space (L x W x H)(approx.)	m	10.4 x 6.5 / 6.8 x 5.4	13.0 x 6.5 / 6.8 x 5.4	14.8 x 6.5 / 6.8 x 5.4	17.3 x 6.5 / 6.8 x 5.4

※ All specification are subjected to change without prior notice.

FG series

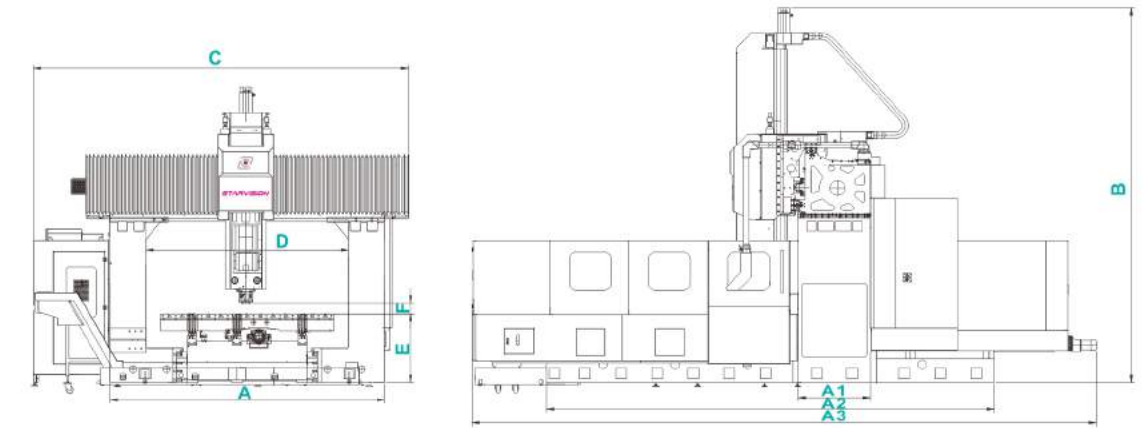

Model	Unit	A	B	C	D	E	F	A1	A2	A3
FG-3226	mm	3,800	5,400	5,800	2,800	950	150	1,000	6,200	8,700
FG-4226	mm	3,800	5,400	5,800	2,800	950	150	1,000	8,200	11,300
FG-5226	mm	3,800	5,400	5,800	2,800	950	150	1,000	10,200	13,100
FG-6226	mm	3,800	5,400	5,800	2,800	950	150	1,000	12,200	15,600
FG-8226	mm	3,800	5,400	5,800	2,800	950	150	1,000	16,200	20,000
FG-10226	mm	3,800	5,400	5,800	2,800	950	150	1,000	20,200	24,400

Model	Unit	FG-3226	FG-4226	FG-5226	FG-6226	FG-8226	FG-10226
Travel							
X axis	mm	3,200	4,200	5,200	6,200	8,200	10,200
Y axis	mm	2,600					
Z axis	mm	1,000 (1,200 opt.)					
Spindle nose to table	mm	150 - 1,150 (150 - 1,350 opt.)					
Distance between columns (max. workpiece width)	mm	2,800 (2,750)					
Table							
Table dimensions (L)	mm	3,000	4,000	5,000	6,000	8,000	10,000
Table dimensions (W)	mm	2,400					
T-slot (width x number x pitch)		28 x 13 x 180					
Max. table load	kg	11,000	13,000	15,000	17,000	21,000	25,000
Spindle							
Spindle motor (cont. / 30 minute rated)	kW	18.5 / 22 (22 / 26 opt.)					
Spindle speed (gear box)	rpm	4,500 (6,000 opt.)					
Spindle taper		BT-50 / ISO-50 / CAT-50					
Feed							
Rapid feed-rate (X / Y / Z)	m/min	15 / 15 / 12	12 / 15 / 12	8 / 12 / 12			
Cutting feed-rate	mm/min	7,000					
Accuracy							
Positioning accuracy	mm	±0.005 / 300; ±0.015 / full travel					
	mm	P0.035					P0.045
Repeatability	mm	±0.003					
	mm	Ps0.028					Ps0.03
ATC							
Tool storage capacity	pcs	32T (24T / 40T / 60T / 90T opt.)					
Max. tool length	mm	350					
Max. tool weight	kg	20					
Tool size (full tools)	mm	Ø125					
Max. tool size (next pockets empty)	mm	Ø245					
Other							
Power consumption	kVA	65					
Compressed air	kg/cm ²	6.5					
Machine weight (approx.)	tons	38	42	48	53	63	83
Machine floor space (L x W x H)(approx.)	m	10.4 x 6.8 x 5.4	13.0 x 6.8 x 5.4	14.8 x 6.8 x 5.4	17.3 x 6.8 x 5.4	21.7 x 6.8 x 5.4	26.1 x 6.8 x 5.4

※ All specification are subjected to change without prior notice.

LS series

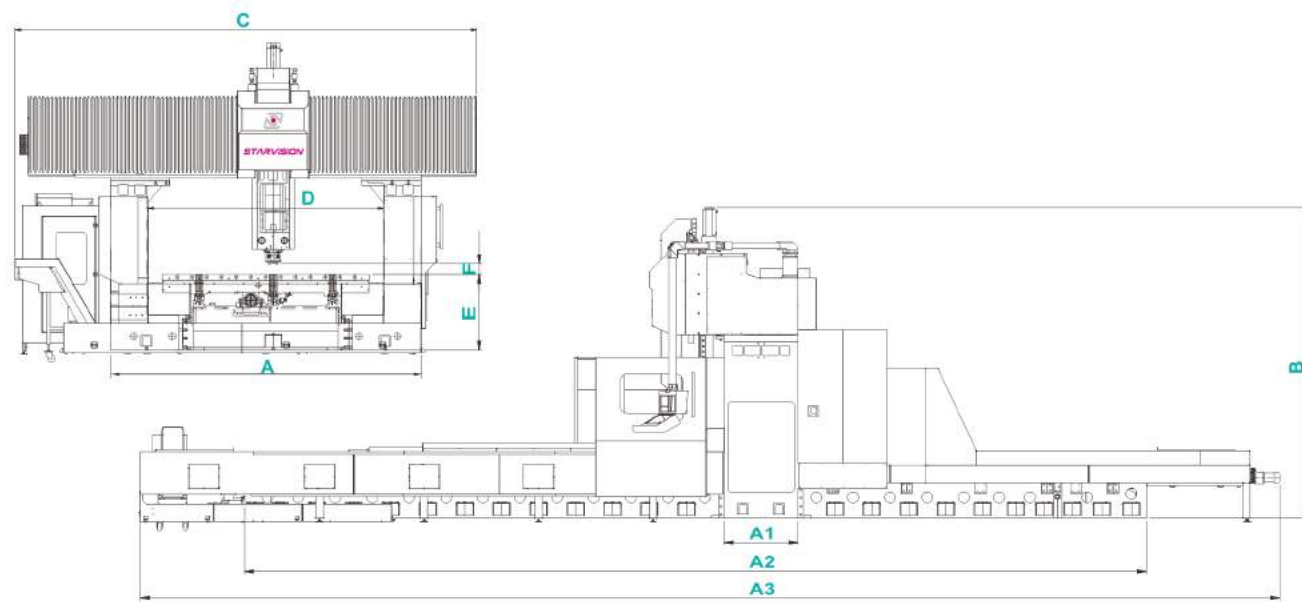

Model	Unit	LS-4230 / 35	LS-5230 / 35	LS-6230 / 35	LS-8230 / 35	LS-10230 / 35
Travel						
X axis	mm	4,200	5,200	6,200	8,200	10,200
Y axis	mm	3,000 / 3,500				
Z axis	mm	1,000 (1,200 opt.)				
Spindle nose to table	mm	150 - 1,150 (150 - 1,350 opt.)				
Distance between columns (max. workpiece width)	mm	3,200 (3,150) / 3,700 (3,650)				
Table						
Table dimensions (L)	mm	4,000	5,000	6,000	8,000	10,000
Table dimensions (W)	mm	2,800 (3,500 opt.)				
T-slot (width x number x pitch)		28 x 13 x 200 (28 x 17 x 200 opt.)				
Max. table load	kg	20,000	24,000	28,000	32,000	40,000
Spindle						
Spindle motor (cont. / 30 minute rated)	kW	18.5 / 22 (22 / 26 opt.)				
Spindle speed (gear box)	rpm	4,500 (6,000 opt.)				
Spindle taper		BT-50 / ISO-50 / CAT-50				
Feed						
Rapid feed-rate (X / Y / Z)	m/min	10 / 10 / 12		8 / 10 / 12		
Cutting feed-rate	mm/min	7,000				
Accuracy						
Positioning accuracy	mm	±0.005 / 300; ±0.015 / full travel				
	mm	P0.045				
Repeatability	mm	±0.003				
	mm	Ps0.03				
ATC						
Tool storage capacity	pcs	32T (40T / 60T / 90T opt.)				
Max. tool length	mm	350				
Max. tool weight	kg	20				
Tool size (full tools)	mm	Ø125				
Max. tool size (next pockets empty)	mm	Ø245				
Other						
Power consumption	kVA	65				
Compressed air	kg/cm ²	6.5				
Machine weight (approx.)	tons	55 / 57	63 / 65	71 / 73	87 / 89	101 / 103
Machine floor space (L x W x H)(approx.)	m	13.8 x 7.3 / 7.8 x 5.4	15.8 x 7.3 / 7.8 x 5.4	17.3 x 7.3 / 7.8 x 5.4	21.7 x 7.3 / 7.8 x 5.4	26.1 x 7.3 / 7.8 x 5.4

※ All specification are subjected to change without prior notice.

Model	Unit	A	B	C	D	E	F	A1	A2	A3
LS-4230 (35/40/45)	mm		5,400			1,020	150	1,100	8,200	12,100
LS-5230 (35/40/45)	mm		5,400			1,020	150	1,100	10,200	14,100
LS-6230 (35/40/45)	mm	4,300 (4,800 / 5,300 / 5,800)	5,400	6,300 (6,800 / 7,300 / 7,800)	3,200 (3,700 / 4,200 / 4,700)	1,020	150	1,100	12,200	15,600
LS-8230 (35/40/45)	mm		5,400			1,020	150	1,100	16,200	20,000
LS-10230 (35/40/45)	mm		5,400			1,020	150	1,100	20,200	24,400

Model	Unit	LS-4240 / 45	LS-5240 / 45	LS-6240 / 45	LS-8240 / 45	LS-10240 / 45
Travel						
X axis	mm	4,200	5,200	6,200	8,200	10,200
Y axis	mm	4,000 / 4,500				
Z axis	mm	1,000 (1,200 / 1,500 opt.)				
Spindle nose to table	mm	150 - 1,150 (150 - 1,350 / 150 - 1,650 opt.)				
Distance between columns (max. workpiece width)	mm	4,200 (4,150) / 4,700 (4,650)				
Table						
Table dimensions (L)	mm	4,000	5,000	6,000	8,000	10,000
Table dimensions (W)	mm	2,800 (3,500 opt.)				
T-slot (width x number x pitch)		28 x 13 x 200 (28 x 17 x 200 opt.)				
Max. table load	kg	20,000	24,000	28,000	32,000	40,000
Spindle						
Spindle motor (cont. / 30 minute rated)	kW	22 / 26				
Spindle speed (gear box)	rpm	4,200				
Spindle taper		BT-50 / ISO-50 / CAT-50				
Feed						
Rapid feed-rate (X / Y / Z)	m/min	10 / 10 / 12		8 / 10 / 12		
Cutting feed-rate	mm/min	7,000			6,000	
Accuracy						
Positioning accuracy	mm	±0.005 / 300; ±0.015 / full travel				
	mm	P0.045				
Repeatability	mm	±0.003				
	mm	Ps0.03				
ATC						
Tool storage capacity	pcs	32T (40T / 60T / 90T opt.)				
Max. tool length	mm	350				
Max. tool weight	kg	20				
Tool size (full tools)	mm	Ø125				
Max. tool size (next pockets empty)	mm	Ø245				
Other						
Power consumption	kVA	65				
Compressed air	kg/cm ²	6.5				
Machine weight (approx.)	tons	66 / 69	74 / 77	82 / 85	98 / 101	112 / 115
Machine floor space (L x W x H)(approx.)	m	13.8 x 8.3 / 8.8 x 5.4	15.8 x 8.3 / 8.8 x 5.4	17.3 x 8.3 / 8.8 x 5.4	21.7 x 8.3 / 8.8 x 5.4	26.1 x 8.3 / 8.8 x 5.4

※ All specification are subjected to change without prior notice.

ACCESSORY LIST

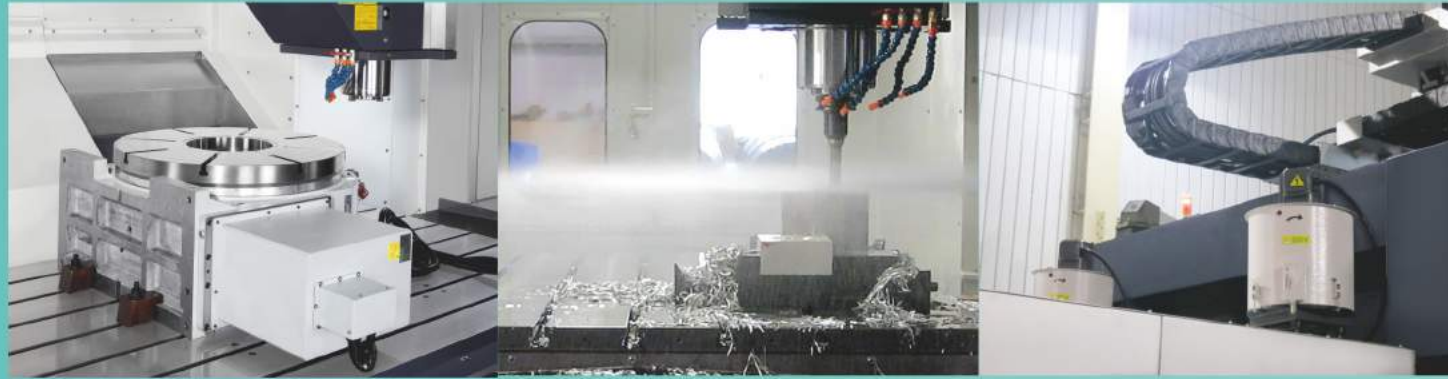

Category	Description	DX	LG	FG	LS
Controller	FANUC Oi-MF controller	●	●	●	●
	FANUC 31i-MB controller	○	○	○	○
	MITSUBISHI M70 controller	○	○	○	○
	SIEMENS 840D controller	○	○	○	○
	HEIDENHAIN TNC640 controller	○	○	○	○
Spindle	18.5/22 kW spindle motor	●	●	●	○
	22/26 kW spindle motor	○	○	○	●
	4,200 2-step gear drive spindle	X	X	X	★
	4,500 2-step gear drive spindle	●	●	●	★
	6,000 2-step gear drive spindle	○	○	○	★
	8,000/10,000rpm direct drive spindle	○	○	○	○
Z travel extension / higher column	Z travel 800mm	●	X	X	X
	Z travel 1,000mm	○	●	●	●
	Z travel 1,200mm	X	○	○	○
	Z travel 1,500mm	X	X	X	★
	100mm higher column (standard Z travel)	X	○	○	X
	200mm higher column (standard Z travel)	○	○	○	○
	300mm higher column (standard Z travel)	○	○	○	X
400mm higher column (standard Z travel)	X	○	○	○	
ATC	Automatic tool changer 32 tools	●	●	●	●
	Automatic tool changer 24 tools	○	○	○	X
	Automatic tool changer 40 / 60 tools	○	○	○	○
	Automatic tool changer 90 / 120 tools	X	○	○	○
Milling head function	Manual: 90° angular milling head / high-speed 2-axis head / 2-axis head / extension head / boring head	○	○	○	○
	Semi-automatic: 90° angular milling head / 2-axis head / extension head / boring head (V/H ATC and AHS inapplicable)	○	○	○	○
	Automatic: 90° angular milling head / 2-axis head / extension head / boring head	X	○	○	○
	Vertical/horizontal automatic tool changer (40 / 60 / 90 tools)	X	○	○	○
	Manual head station (Table type)	○	○	○	○
	Manual head station (Arm type)	○	○	○	○
Automatic head station	X	○	○	○	

Optional: ○ Standard: ● N/A: X Depending on the model: ★

Category	Description	DX	LG	FG	LS
Splash guard	Semi splash guard	○	○	★	●
	Fully enclosed splash guard (roof excluded)	●	●	★	○
	Fully enclosed splash guard (roof included)	○	○	★	X
Mechanical	X / Y / Z axes absolute pulse coder	●	●	●	●
	Rigid tapping	●	●	●	●
	Twin hydraulic cylinders	●	●	●	●
	Nitrogen balancing system	●	●	●	●
	Automatic lubrication system	●	●	●	●
	Spindle oil cooler	●	●	●	●
	Air blast through spindle	●	●	●	●
	Manual pulse generator	●	●	●	●
	Working lamp	●	●	●	●
	3-color alarm lamp	●	●	●	●
	RS-232 interface	●	●	●	●
	Heat exchanger for electrical cabinet	●	●	●	●
	Water gun and air gun interface	●	●	●	●
	Cutting coolant unit	●	●	●	●
	Twin auger chip removal system	●	●	●	●
	Belt type chip conveyor with cart	●	●	●	●
	Sub-table	○	○	○	○
	3 axes manual pulse generator for mold processing	○	○	○	○
	Coolant through spindle at 20 / 40 / 70 bar	○	○	○	○
	Coolant through tool holder interface	○	○	○	○
	Air conditioner for electrical cabinet	○	○	○	○
	Oil skimmer	○	○	○	○
Transformer	○	○	○	○	
Oil mist device	○	○	○	○	
Measurement	HEIDENHAIN linear scale	○	○	○	○
	Automatic tool measuring system	○	○	○	○
	Automatic work piece measuring system	○	○	○	○
4 th axis function	CNC rotary table	○	○	○	○
	4 th axis preparation	○	○	○	○
Others	Leveling bolts & blocks	●	●	●	●
	Tool box	●	●	●	●
	CE norm	○	○	○	○